

Mechanical jib 13t@2m

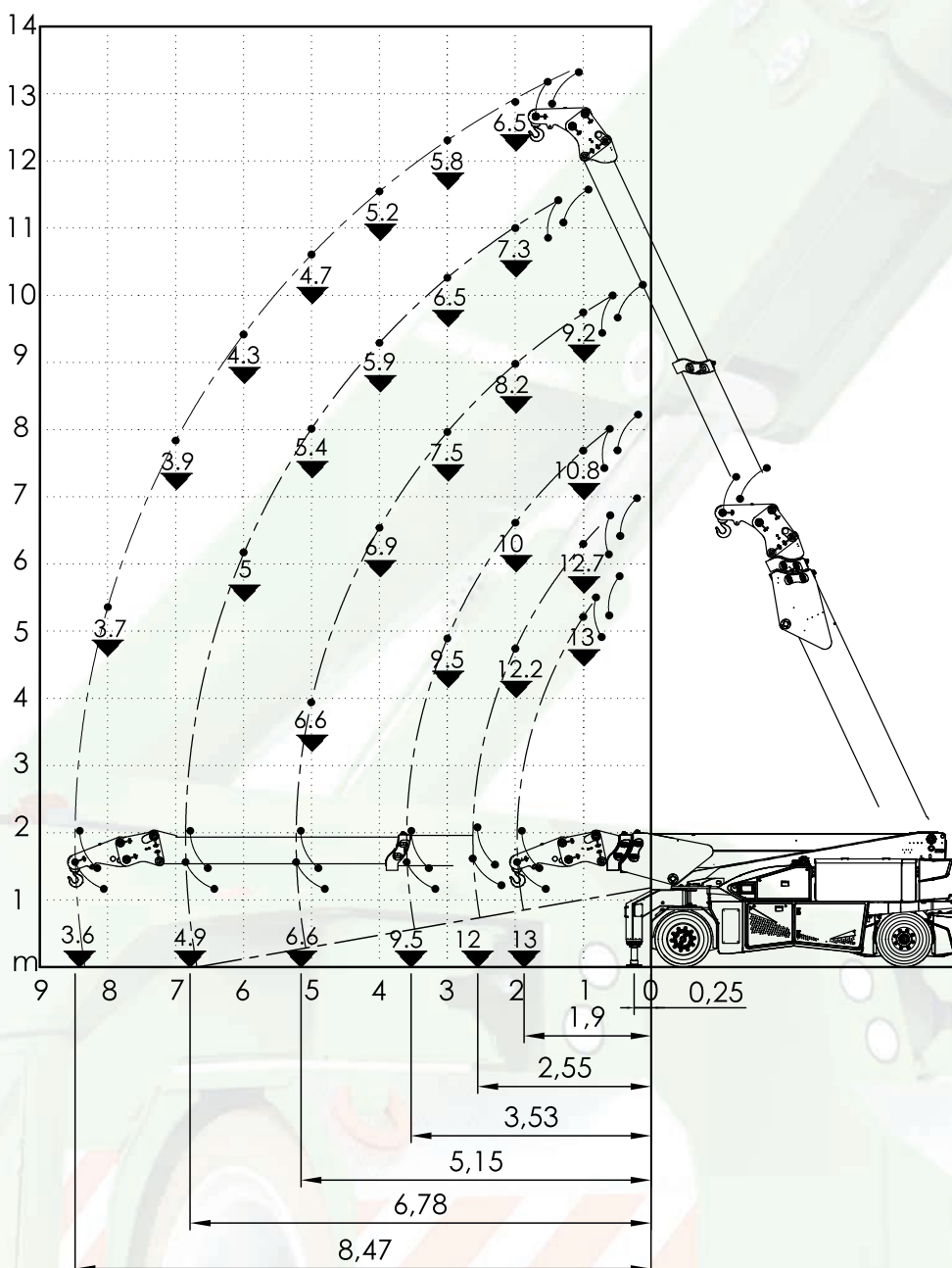

Load charts



Mechanical jib 13t@2m

Hook

3 counterweights + stab. open at 250 mm

Maximum capacity

Hook: 13t

Mechanical jib 13t@2m



Load charts

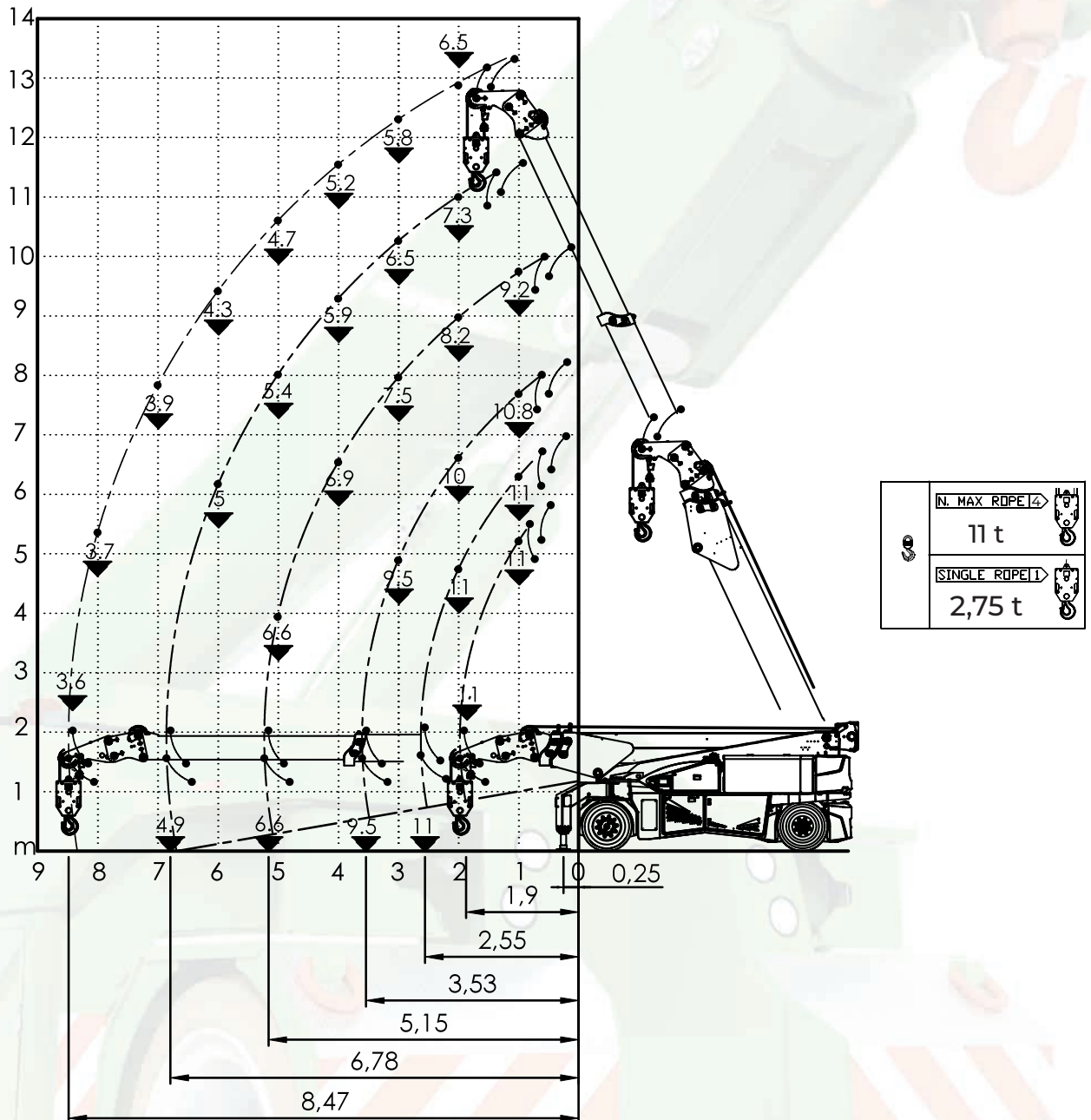

Mechanical jib 13t@2m

Winch

3 counterweights + stab. open at 250 mm

Maximum capacity

Winch: 11t

Mechanical jib 13t@2m



Load charts

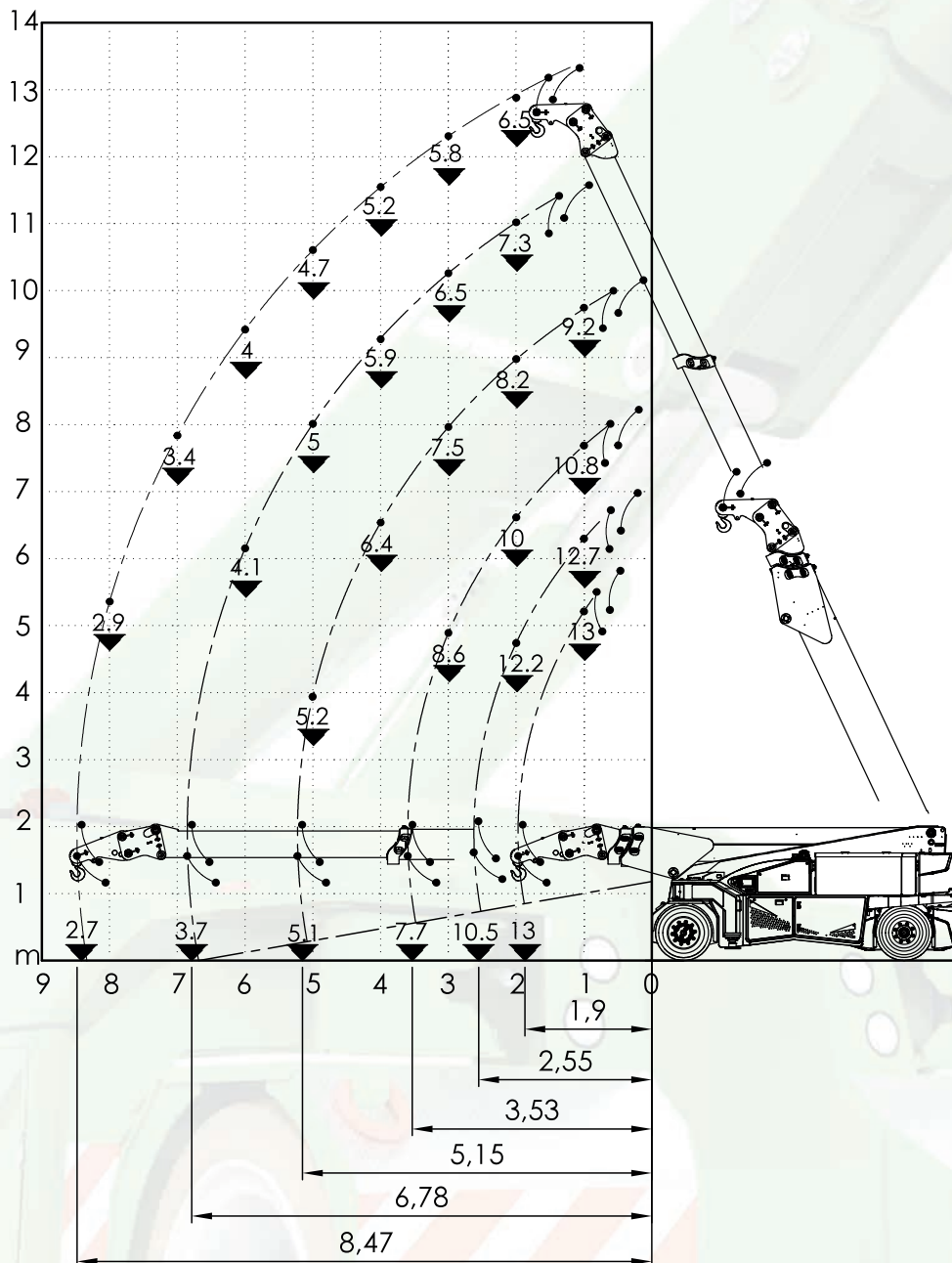

Mechanical jib 13t@2m
 Hook
 3 counterweights

Maximum capacity
 Hook: 13t

Mechanical jib 13t@2m



Load charts

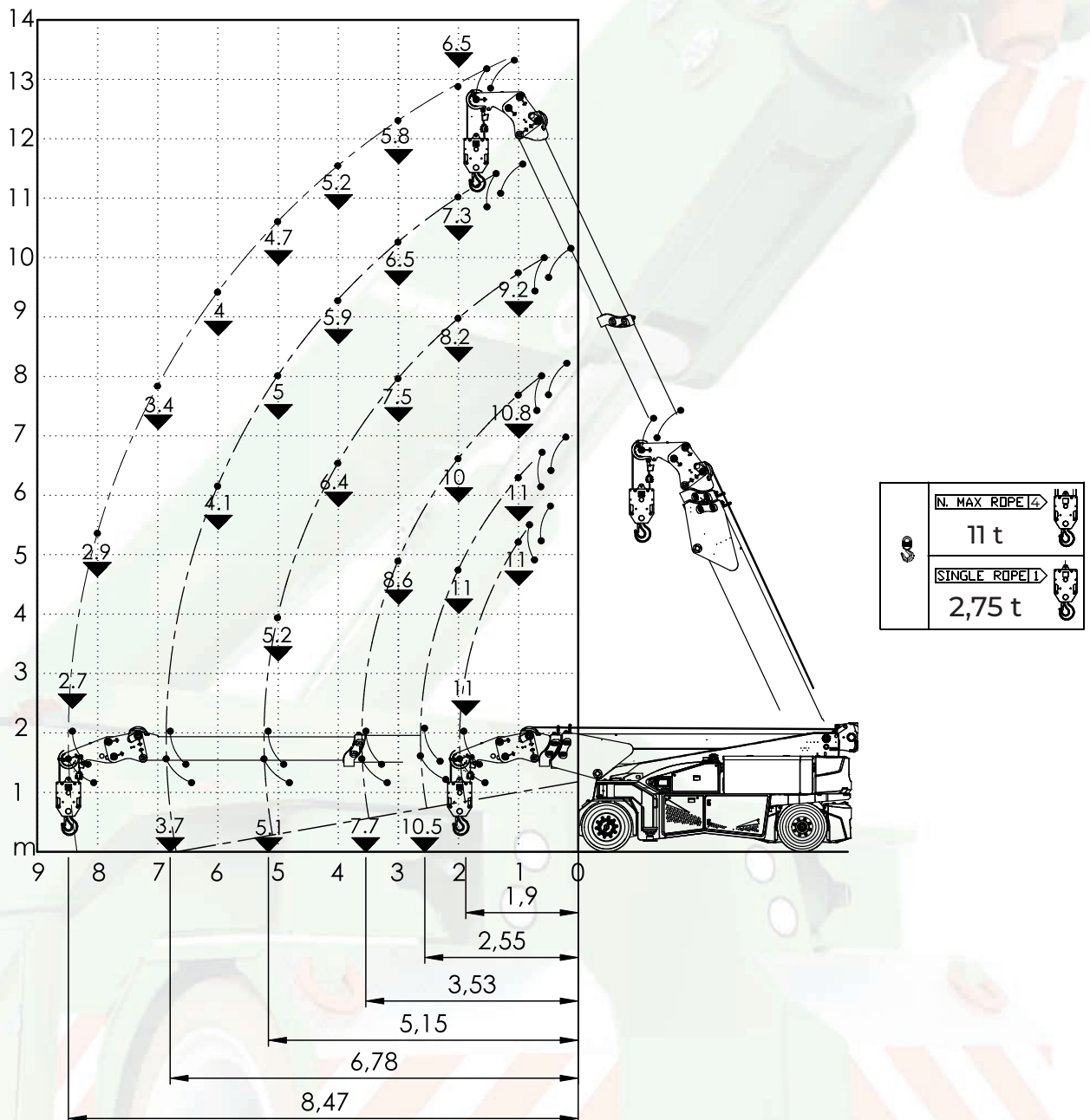

Mechanical jib 13t@2m
Winch
3 counterweights

Maximum capacity
Winch: 11t

Hydraulic jib 7t@2.2m



Load charts

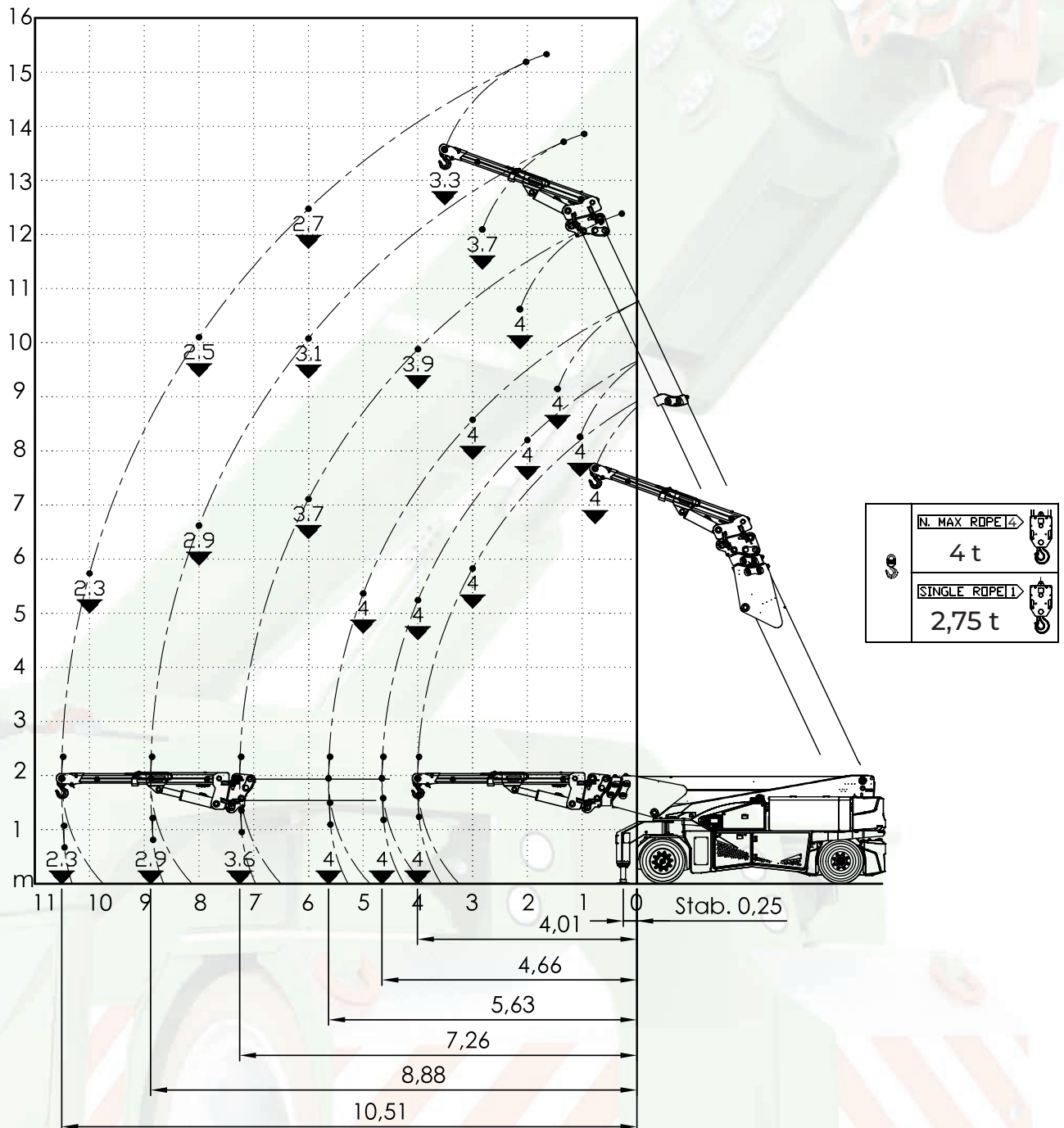

Hydraulic jib 7t@2.2m

Hook/Winch

3 counterweights + stab. open at 250 mm

Extended

Hydraulic jib 7t@2.2m



Load charts

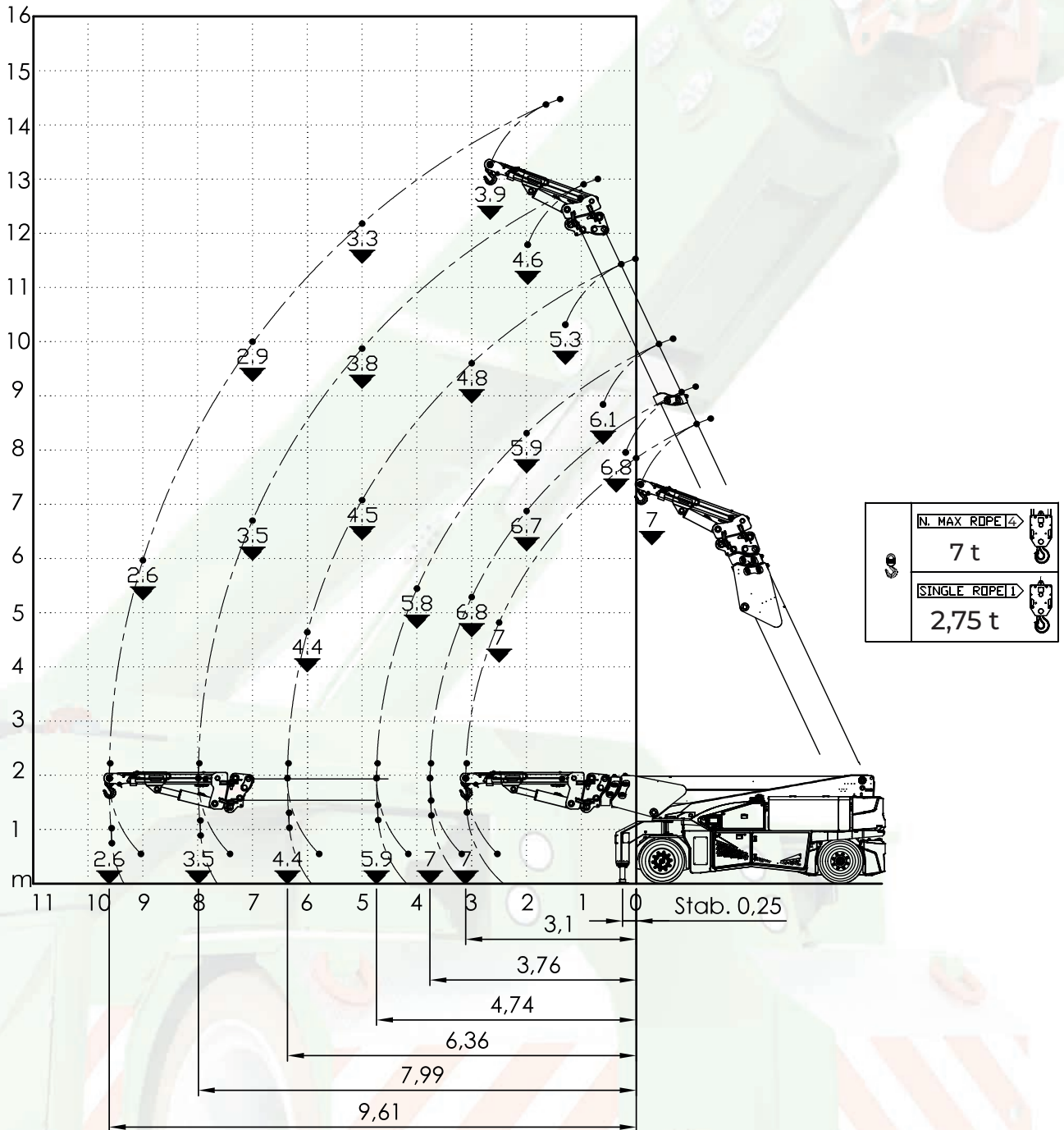

Hydraulic jib 7t@2.2m

Hook/Winch

3 counterweights + stab. open at 250 mm

Retracted

Maximum capacity

7t

Hydraulic jib 7t@2.2m



Load charts

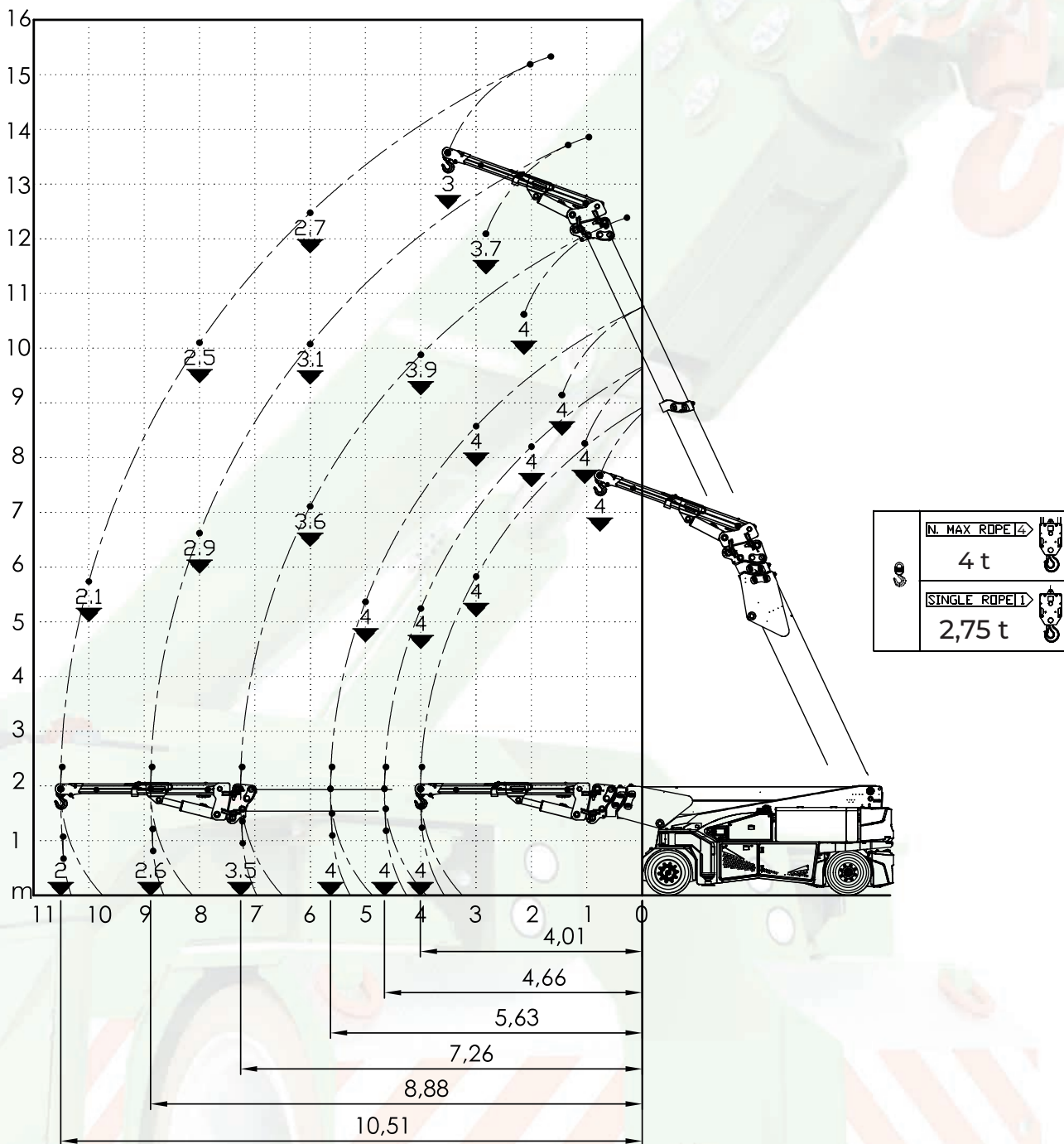

Hydraulic jib 7t@2.2m

Hook/Winch

3 counterweights

Extended

Hydraulic jib 7t@2.2m



Load charts

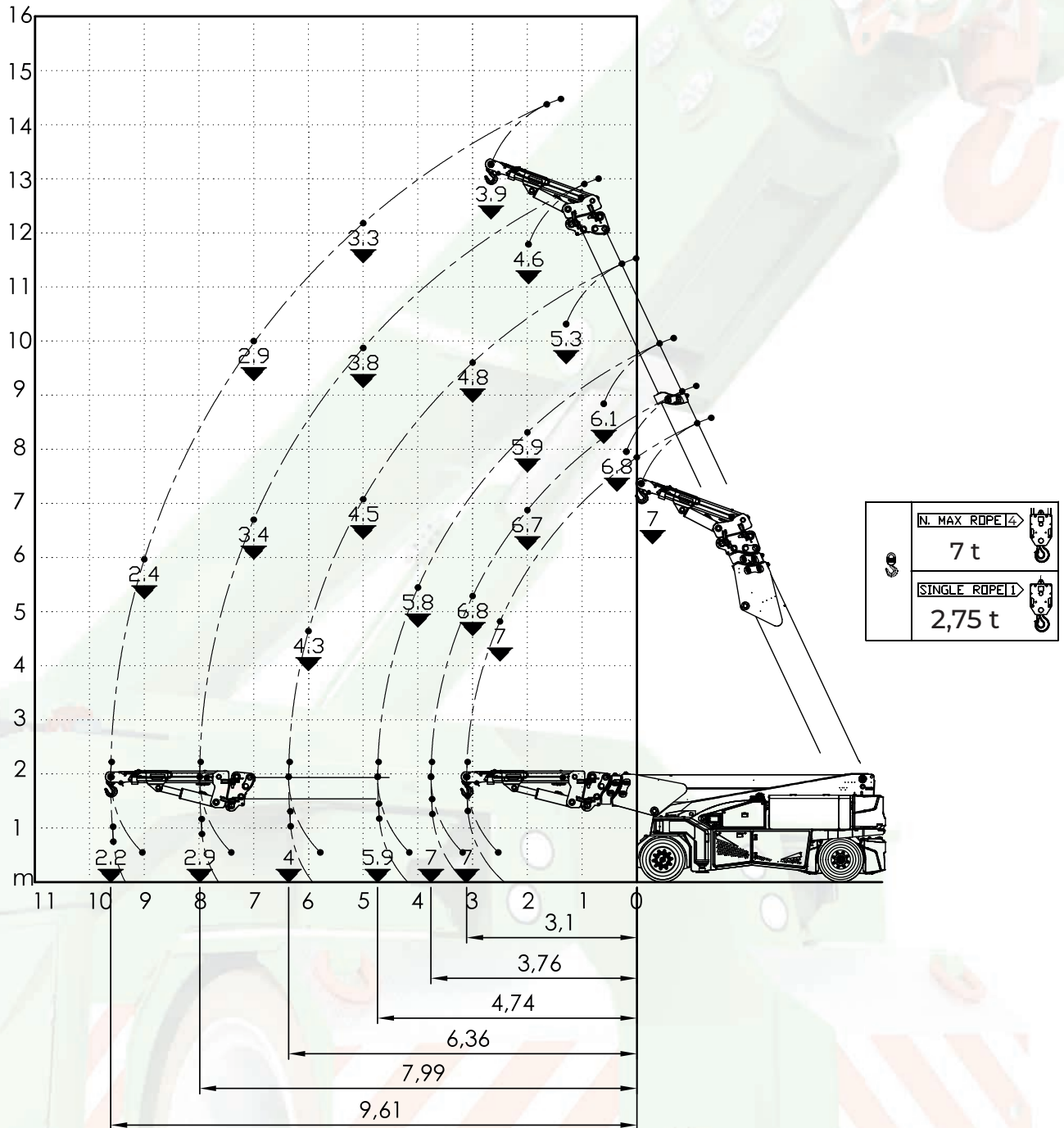

Hydraulic jib 7t@2.2m

Hook/Winch

3 counterweights

Retracted

Maximum capacity
7t

Hydraulic jib F63



Load charts

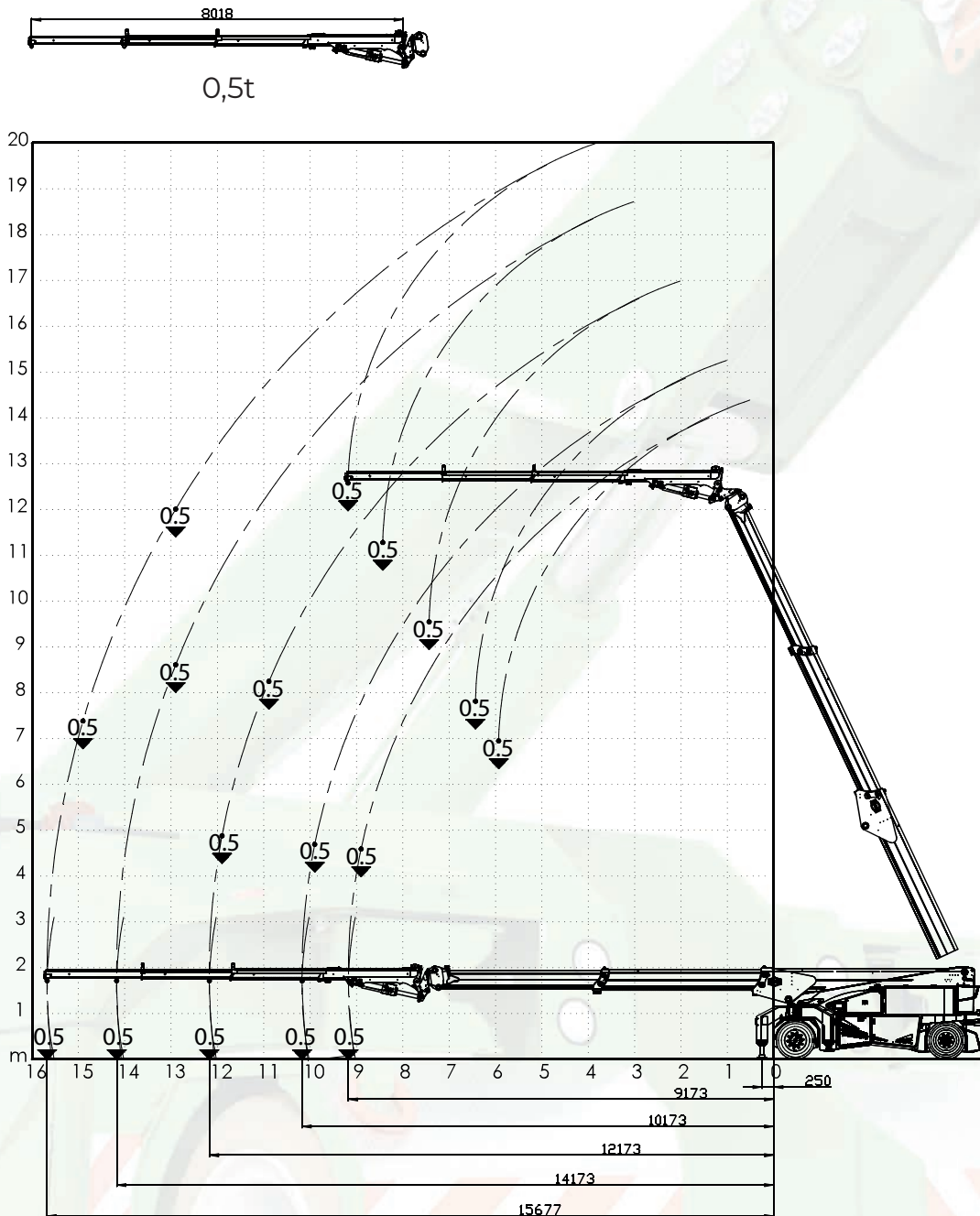

Hydraulic jib F63

Hook

3 counterweights + stab. open at 250 mm

Extended

Hydraulic jib F63



Load charts

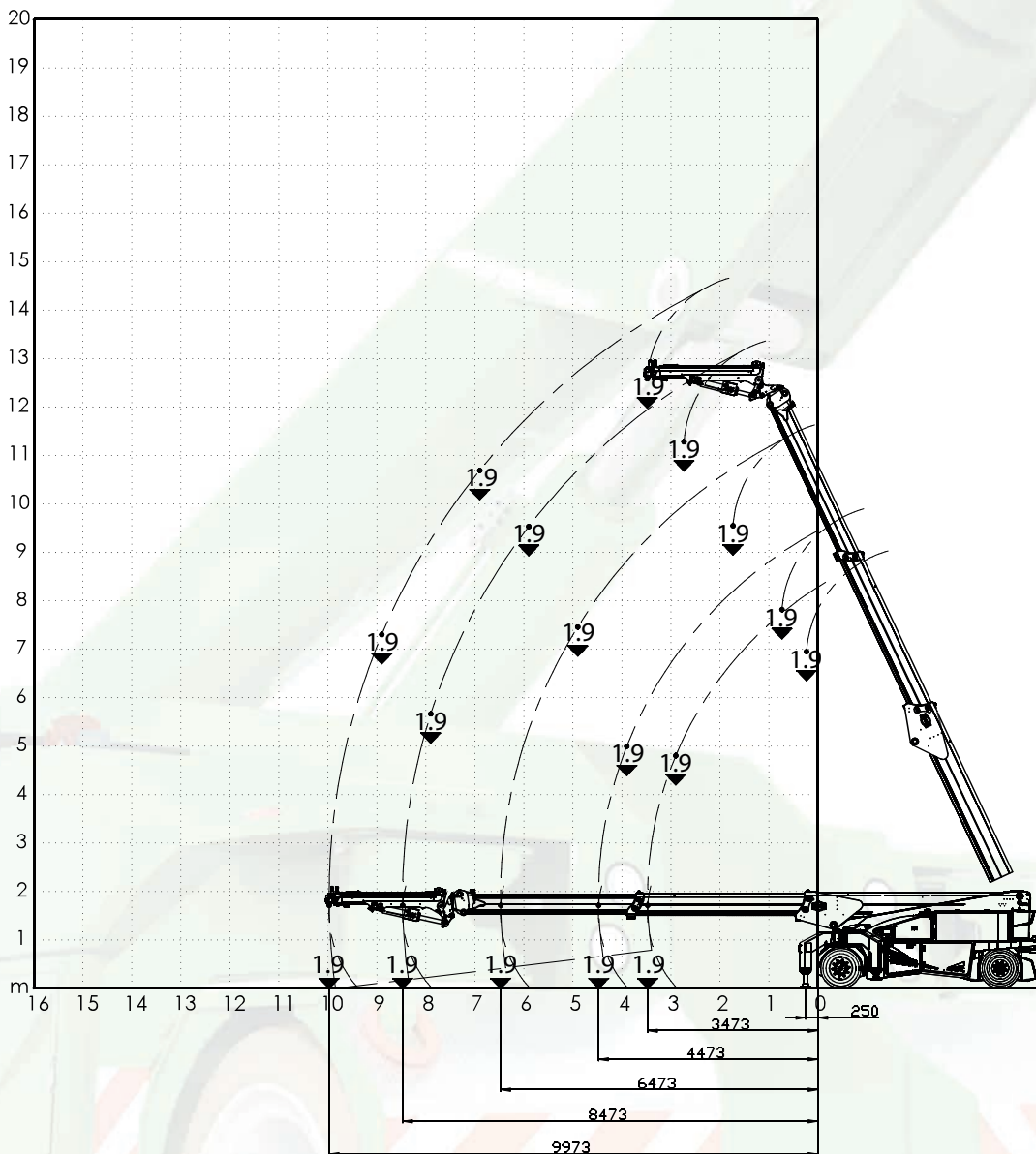
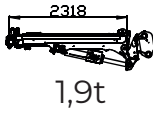

Hydraulic jib F63

Hook

3 counterweights + stab. open at 250 mm

Retracted

Maximum capacity
1,9t

Hydraulic jib F63



Load charts

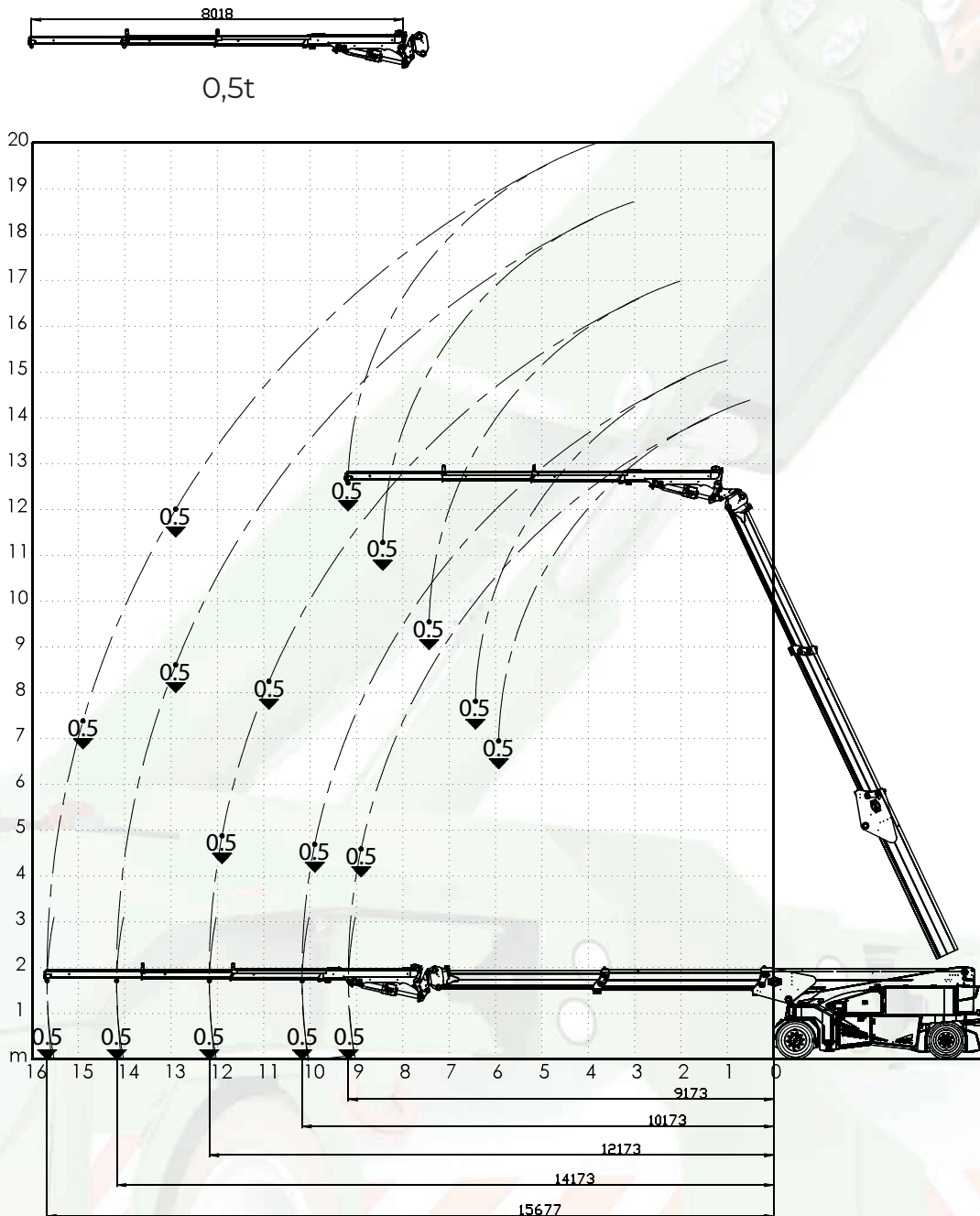

Hydraulic jib F63

Hook

3 counterweights

Extended

Hydraulic jib F63



Load charts

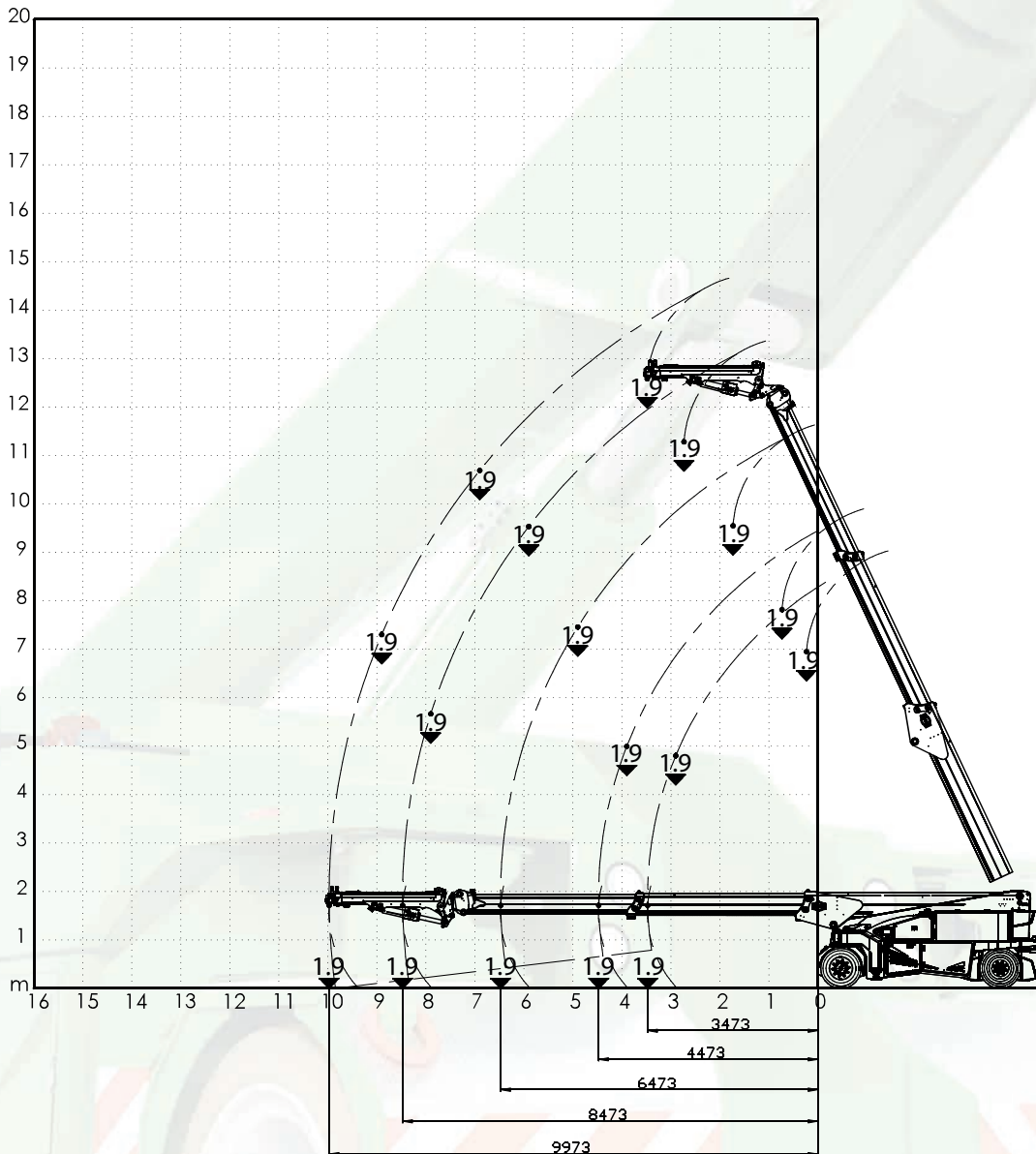
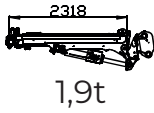

Hydraulic jib F63

Hook

3 counterweights

Retracted

Maximum capacity
1,9t

Forks 12t@0.5m



Load charts

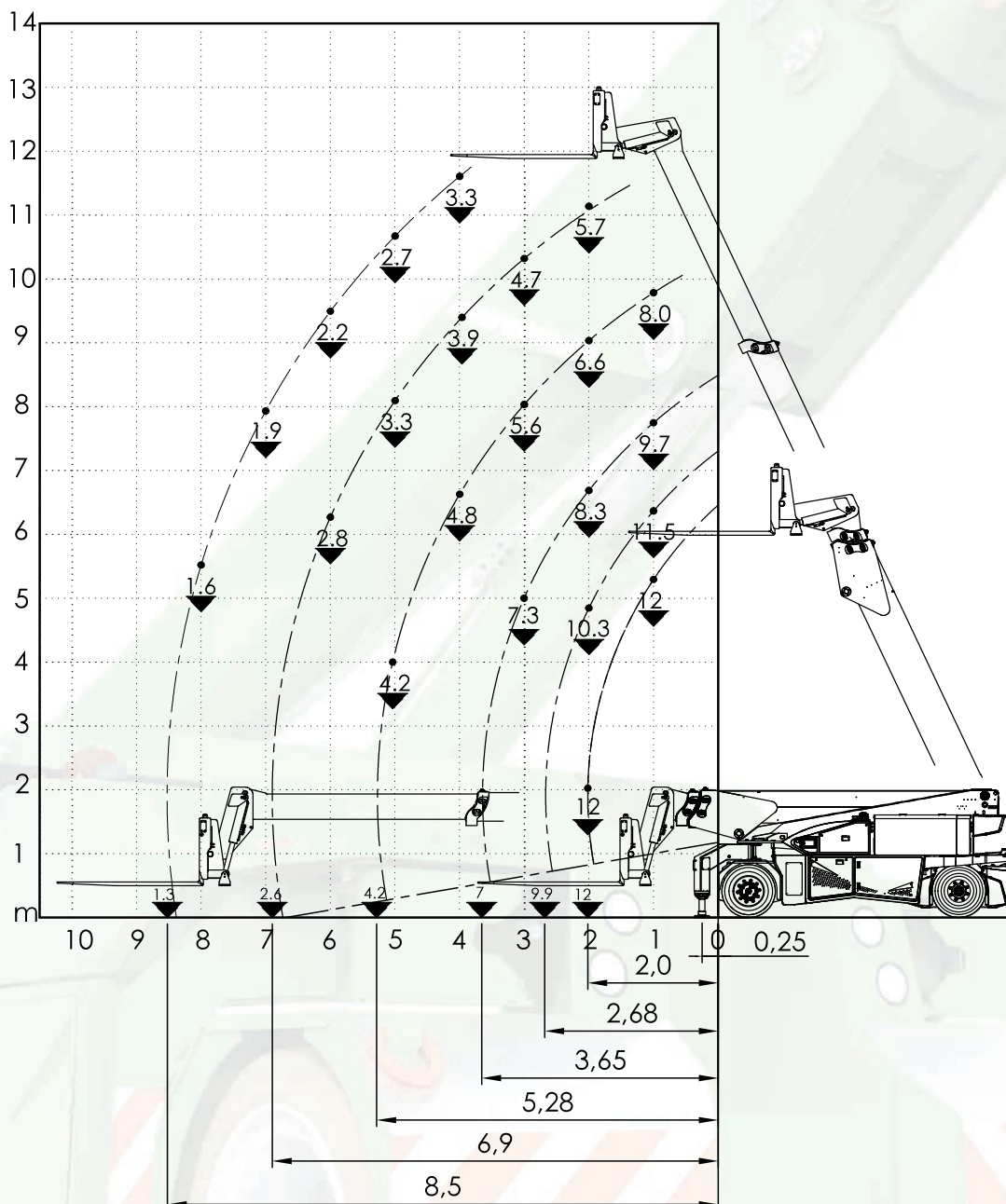

Forks 12t@0.5m

3 counterweights + stab. open at 250 mm

Maximum capacity
12t

Forche 12t@0.5m



Load charts

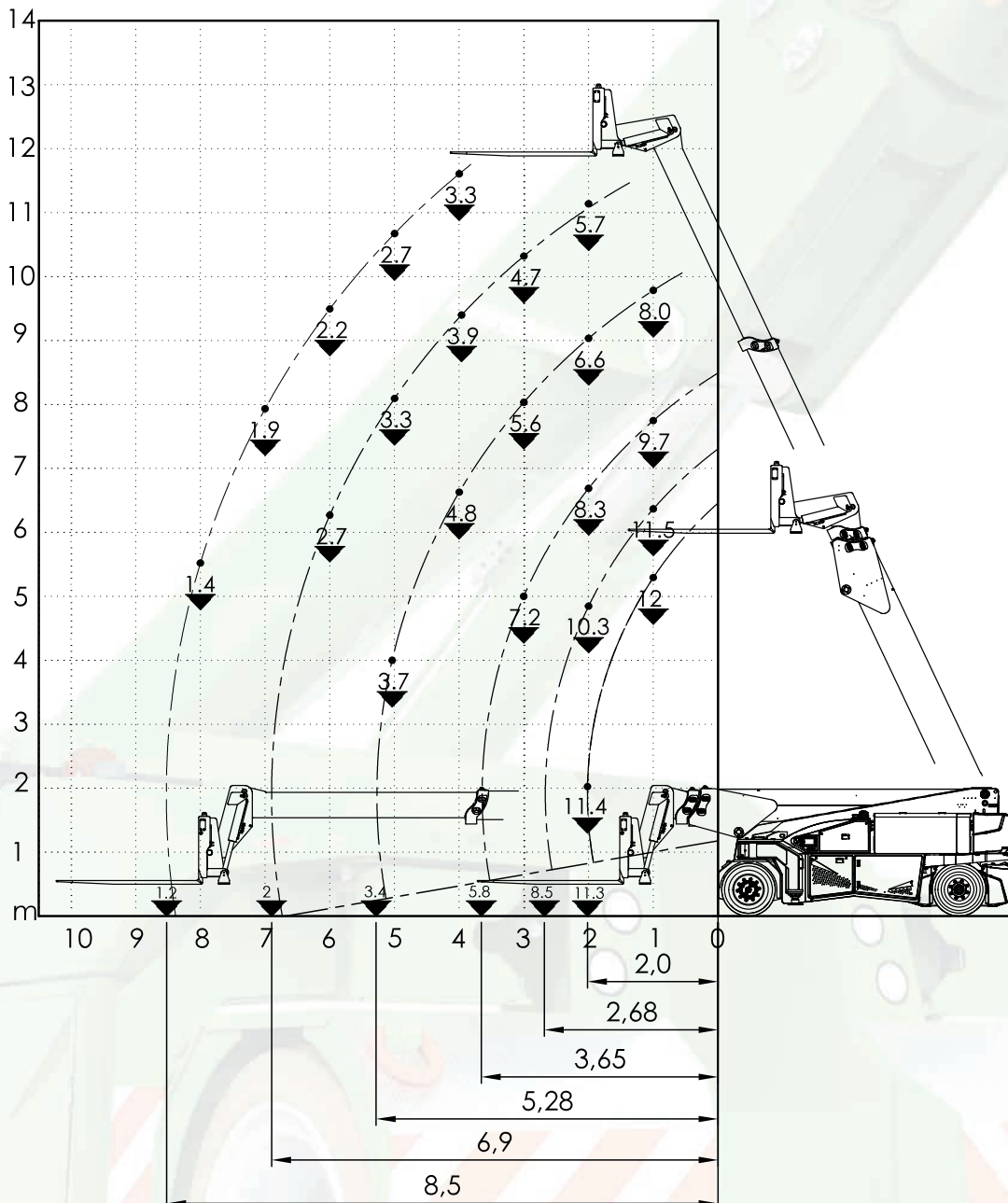

Forks 12t@0.5m
3 counterweights

Maximum capacity
12t