







Extension 0.4t@0.8m on mechanical jib

	N. MAX ROPE I	
	0,4 t	
	SINGLE ROPE I	
	0,8 t	





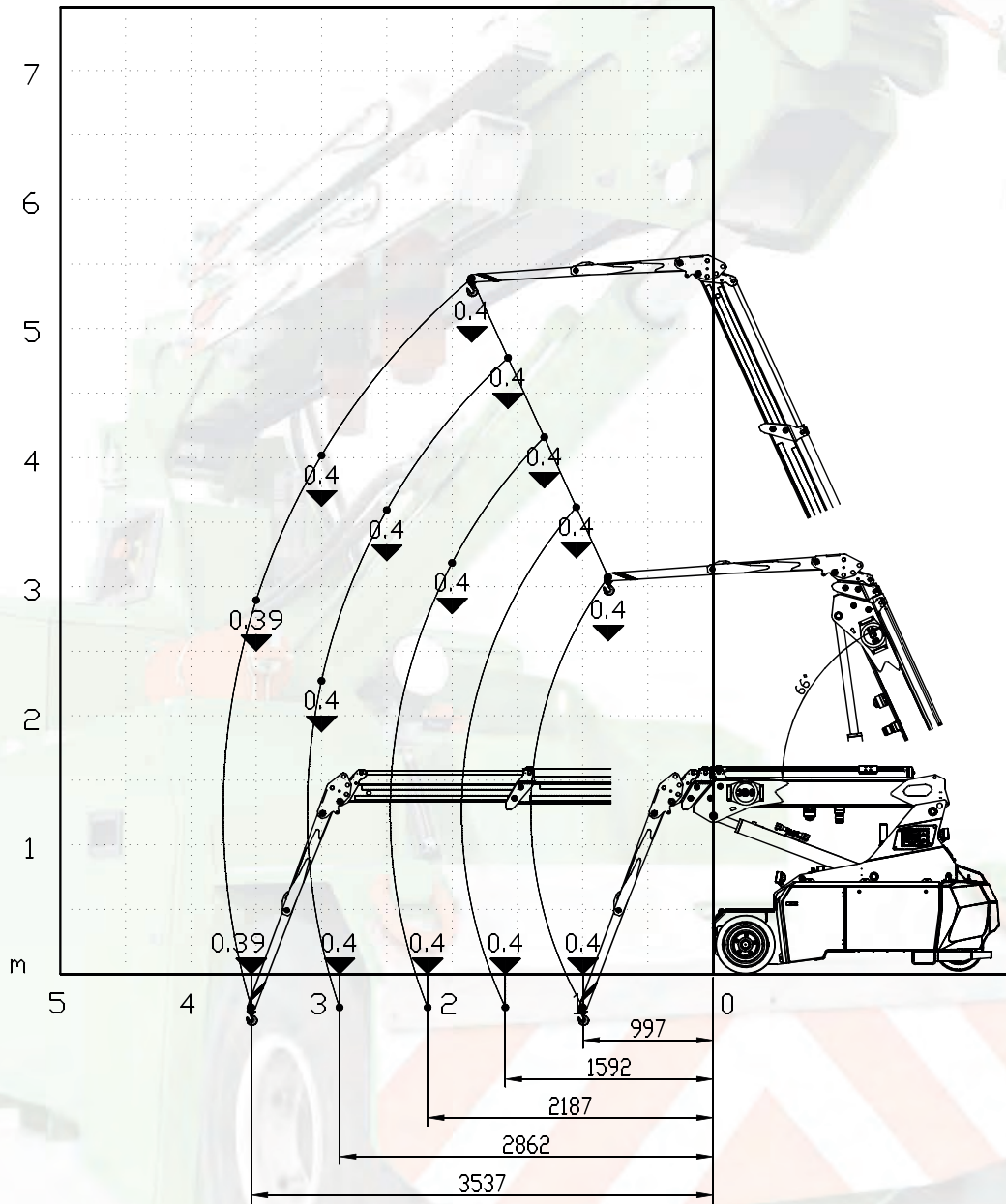



Load charts



Extension 0.4t@0.8m
 Mechanical jib
 Hook / Winch
 Position 1
 1 counterweight

Maximum capacity
 Hook/Winch: **0,4t**

Extension 0.4t@0.8m on mechanical jib

	N. MAX ROPE I	
	0,4 t	
	SINGLE ROPE I	
	0,8 t	





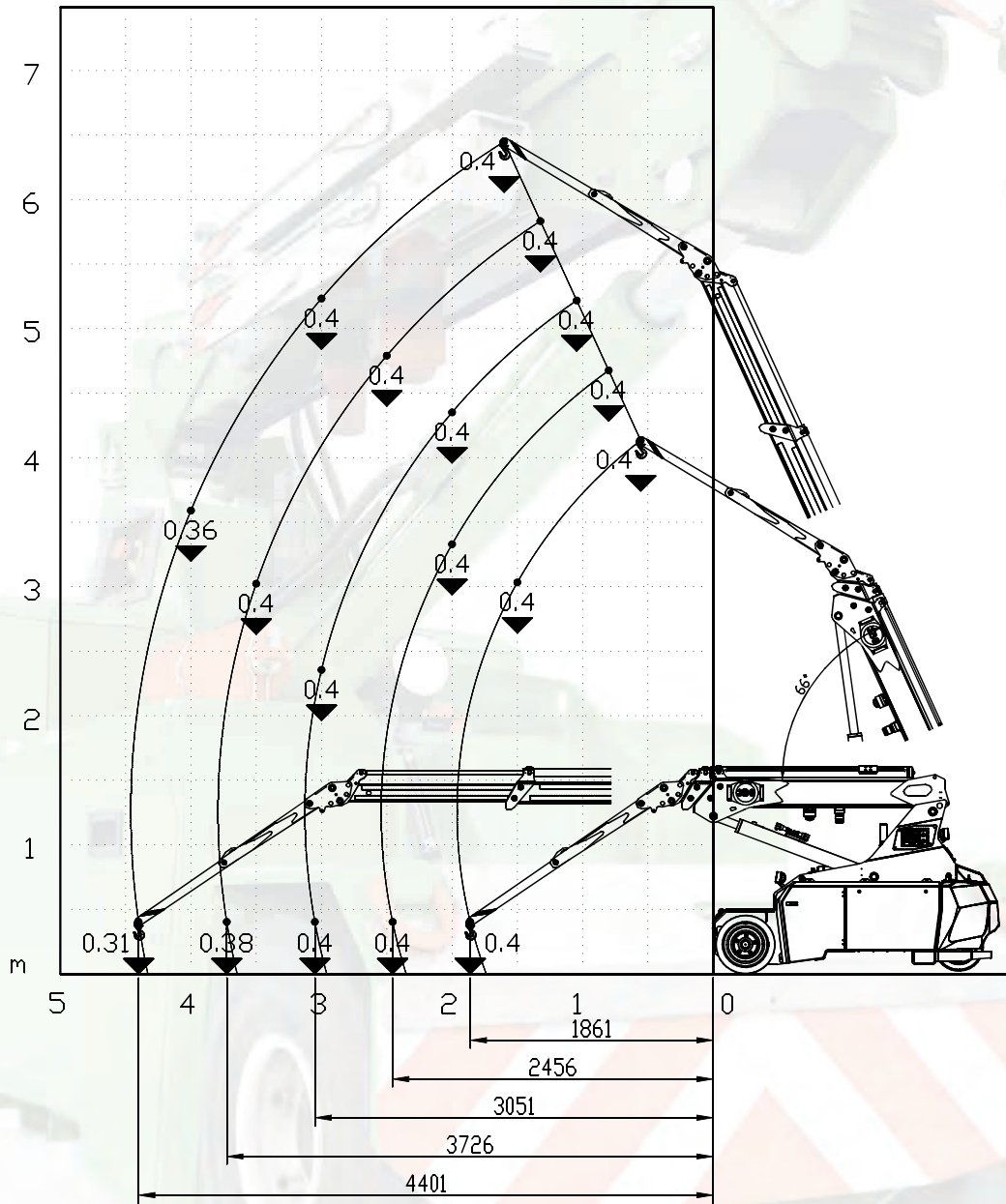



Load charts



Extension 0.4t@0.8m
 Mechanical jib
 Hook / Winch
 Position 2
 1 counterweight

Maximum capacity
 Hook/Winch: **0,4t**

Extension 0.4t@0.8m on mechanical jib

	N. MAX ROPE I	
	0,4 t	
	SINGLE ROPE I	
	0,8 t	



Load charts

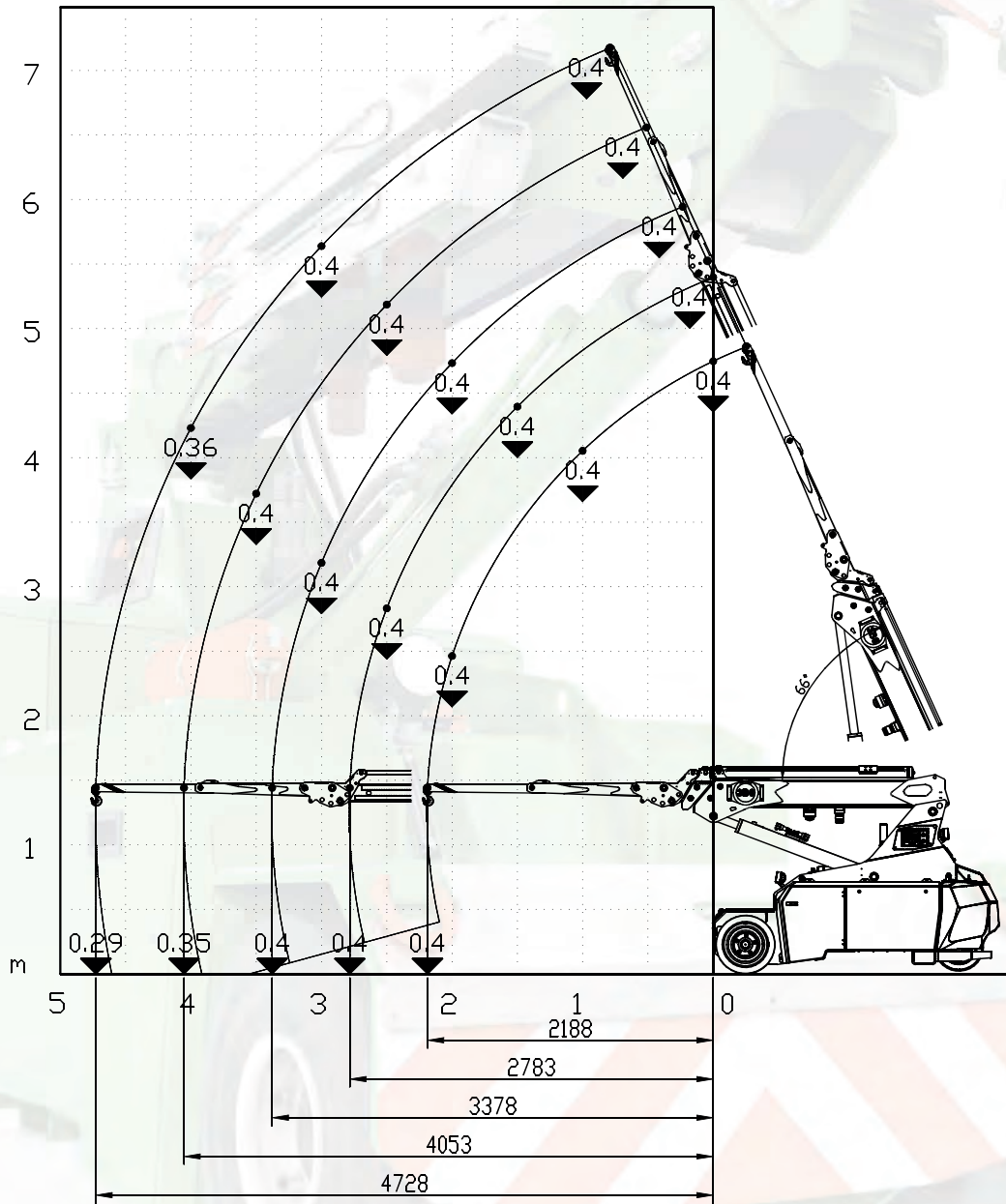

Extension 0.4t@0.8m
 Mechanical jib
 Hook / Winch
 Position 3
 1 counterweight

Maximum capacity
 Hook/Winch: **0,4t**

Mechanical jib 1t@0.8m



Load charts

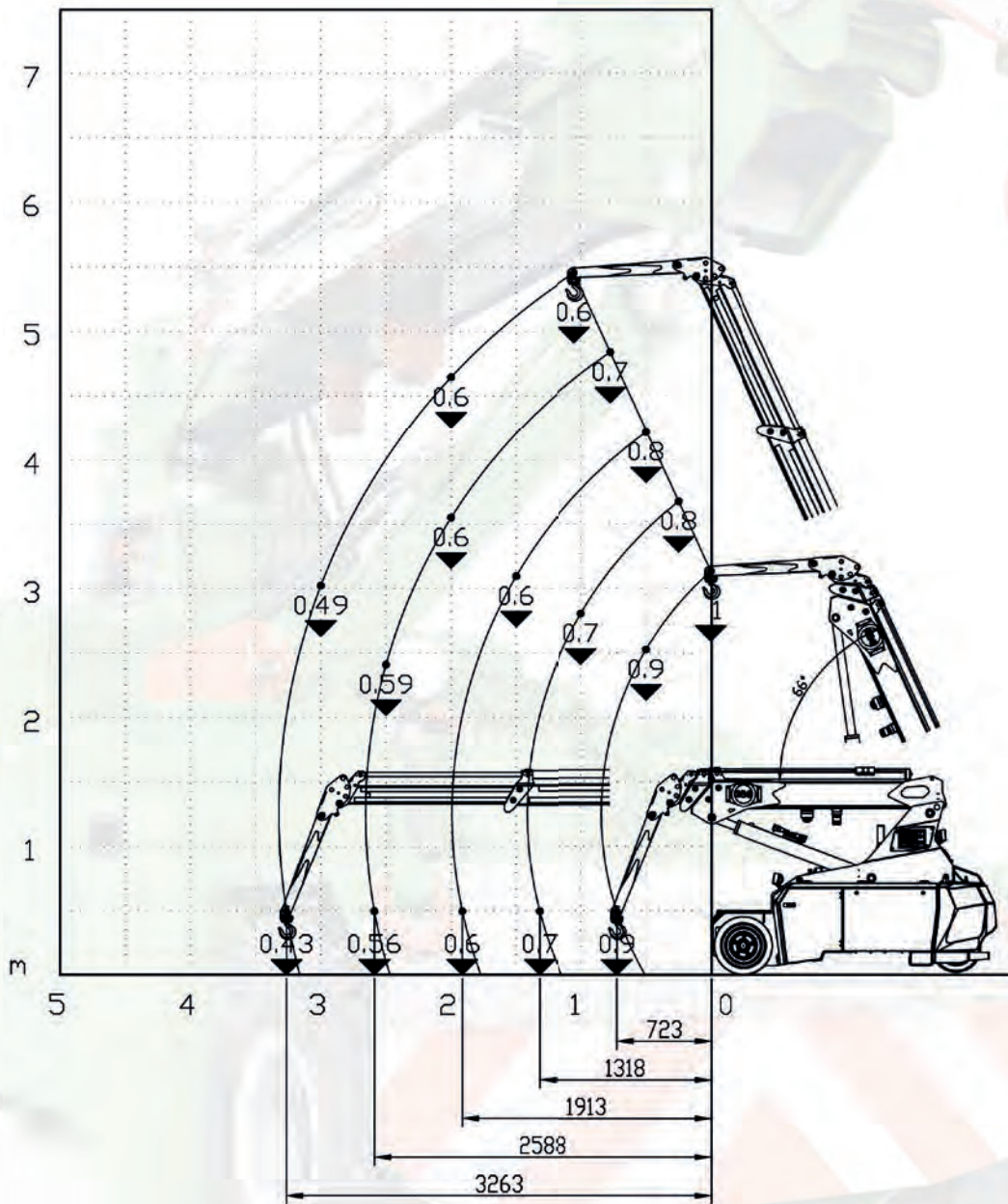

Mechanical jib 1t@0.8m





Hook

1 counterweight

Maximum capacity

Hook: 1t

Mechanical jib 1t@0.8m

	N. MAX ROPE 1	
	0,8 t	
	SINGLE ROPE 1	
	0,8 t	



Load charts

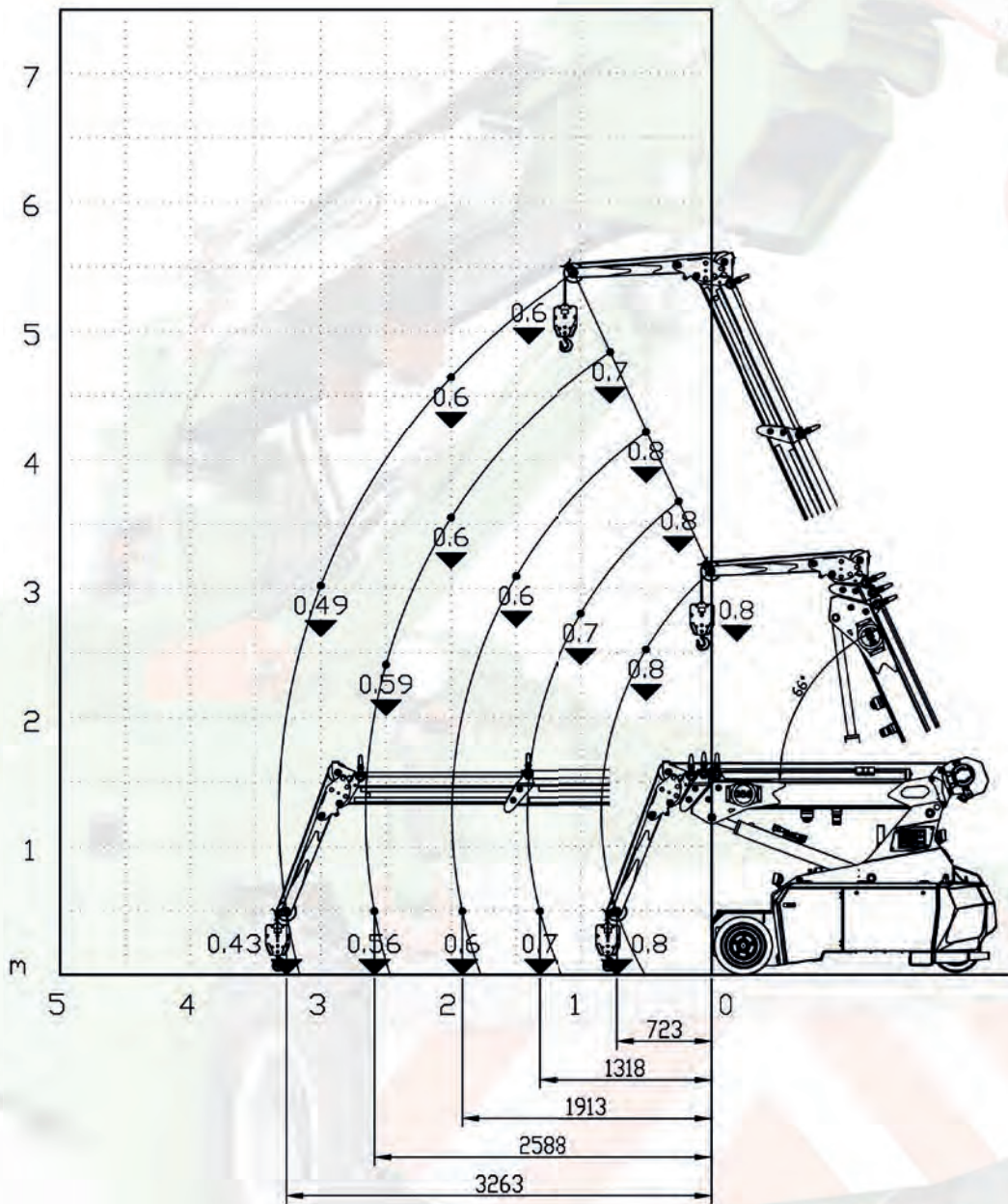

Mechanical jib 1t@0.8m
Winch
1 counterweight

Maximum capacity
Winch: **0,8t**